



## Dual control of solar-powered water control system for overhead and reservoir tanks

Kabiru Adamu Sa'idu<sup>1\*</sup>, M A Sule<sup>2</sup>, U S Ibrahim<sup>1</sup>, A Jibrin<sup>1</sup>

<sup>1</sup> Department of Elect. /Electronics Engineering, Federal Polytechnic Kaltungo, Gombe, Nigeria

<sup>2</sup> Department of Computer Engineering Technology, Federal Polytechnic Kaltungo, Gombe, Nigeria

### Abstract

In this study, the development of an automatic water level detection and control system using a waterproof ultrasonic sensor, A02YYUW was considered. Two sensors were used to detect the depth of the water level in both the elevated and the reservoir tanks. Control signals were then sent to microcontroller, ATmega328P for switching the pump on or off, as appropriate. The purpose of the research is to provide continuous supply of water at all times, eliminate the labour associated with turning the water pump on and off, reduce cost of fuelling an electric generator to power the water pump and to protect the water pump from running on empty tank, which may cause its total damage. The experimental results showed the sensor producing more accurate measurements at moderate ambient temperatures, as compared with the actual measurements of the water level from the sensor. The proposed system can be used for monitoring and control of distances in areas where the involvement of human can be catastrophic.

**Keywords:** Arduino uno, ultrasonic sensor, solar photovoltaic module, atmega328p, a02yyuw

### Introduction

The access to clean water and its abundance for use in drinking, sanitation and general cleanliness are some of the key challenges to every world community, especially in African rural regions (Argaw, *et al.*, 2003) [1]. Water boreholes are usually being drilled, especially in the rural areas, so as to cushion the effects of water shortages, but the scarcity of electricity supply in some part of the continent has become a hindrance to continuous supply of portable water to most of its settlements (Ncube & Pili, 2022) [7]. Therefore, the need to have an alternative source that is affordable, reliable, robust and environmentally sustainable. Solar powered systems typically move water over an extended period of time and are able to operate autonomously in most cases (Rashid, *et al.*, 2015) [10]. This can help reduce the pressure on boreholes by spreading yield throughout the day. The tank storage capacity of such systems can also help provide an important buffer, allowing spare water to be used during peak demand times, at night or during periods of intense cloud cover (Bamford & Zadi, 2016) [2].

The solar-powered water pumping system was found to be most suitable alternative source that fulfilled the aforementioned requirements, considering the area of application of this research (that is, School of Engineering building, Federal Polytechnic Kaltungo, Gombe State) due to its abundance solar energy and hot temperatures (Hamza, *et al.*, 2018) [4].

### Methods

The proposed system works on the principle of controlling the water level in the two tanks; both reservoir and elevated tanks, in order to control water overflow in both tanks, maintain constant availability of water in the elevated tank, which supplies the building and give protection to the water pump when there is water in the reservoir tank.

### Solar PV array sizing and layout

The power required to keep the system running would be based on solar system due to the abundance of sun energy at the site of installation. Once the pump has been selected it will be possible to estimate how much energy needs to be generated to power it.

For any type of PV pumping system, the total energy generated by the PV generator can be estimated by the following expression:

$$E_{generated} = P_{peak} \times PSH \times PR \quad (1)$$

Where  $P_{peak}$  is the peak power of the PV generator at standard temperature conditions (STC).

PSH (peak sun hours) is the equivalent number of hours per day when solar irradiance averages  $1000W/m^2$ .

PR (performance ratio) quantifies the reduction in solar energy generated due to system losses.

Similarly, the total energy demand of the pump is given by:

$$E_{pump} = P_1 \times \text{Hours of operation} \quad (2)$$

Where  $P_1$  is the power absorbed by the pump from power source

Equating Equation (1) with (2), we have;

$$P_{peak} = \frac{P_1 \times \text{Hours of operation}}{PSH \times PR}$$

Therefore, the quantity of modules required is given by;

$$N_m = \frac{P_{peak}}{\text{Module's Rating}} \quad (3)$$

Kaltungo town is located on Latitude  $9^\circ 48' 54''N$  and Longitude  $11^\circ 18' 24''E$  (Onoja, *et al.*, 2017) [9]. The average annual solar irradiance and peak sun hours (PSH) for the location are  $5.8kWh/m^2$  and  $7.8hrs$  respectively (NJOKU, *et al.*, 2022) [8].

Once the power of the pump ( $P_1$ ), hours of operation on solar, PSH in the location and an estimated PR are known, it will be possible to calculate the  $P_{peak}$  (or the PV generator size to be installed). Therefore, for a **2Hp** water pump, we have;

$$1Hp = 745.7W$$

$$\therefore 2Hp = 2 \times 745.7W = 1,491.4W$$

This value can be rounded up to  $1,500W = 1.5kW$

Therefore,  $P_1 = 1,500W$ . If the water pump will be operated at 5 hours daily, the PSH as given above being  $7.8hrs$ , and considering the following losses (as performance ratio, PR):

- Losses due to temperature,  $L_{temp} = 10 \text{ per cent}$
- Wiring losses,  $L_{temp} = 3 \text{ per cent}$
- Losses due to soiling/dirt,  $L_{soiling} = 5 \text{ per cent}$
- Losses due to reflectance  $L_{ref} = 3 \text{ per cent}$
- Losses due to incorrect orientation,  $L_{orientation} = 2 \text{ per cent}$
- Losses due to incorrect tilt,  $L_{tilt} = 3 \text{ per cent}$
- Loss due to power tolerance,  $L_{tolerance} = 3 \text{ per cent}$
- Losses due to mismatching,  $L_{mismatch} = 2 \text{ per cent}$
- Losses due to conversion =  $3 \text{ per cent}$
- Losses due to light-induced degradation,

$$L_{LID} = 3 \text{ per cent}$$

Then

$$PR = (1 - 0.1) \times (1 - 0.03) \times (1 - 0.05) \times (1 - 0.03) \times (1 - 0.02) \times (1 - 0.03) \times (1 - 0.05) \times (1 - 0.02) \times (1 - 0.03) \times (1 - 0.03)$$

$$= 0.90 \times 0.97 \times 0.95 \times 0.97 \times 0.98 \times 0.97 \times 0.97 \times 0.98 \times 0.97 \times 0.97$$

$$= 0.684$$

$$\therefore P_{peak} = \frac{P_1 \times \text{Hours of operation}}{PSH \times PR} = \frac{1500 \times 5}{7.8 \times 0.684} = \frac{7500}{5.3352} = 1,405.8W$$

The solar panel intended to use for the research has maximum power rating of  $420Wp$ , therefore, the number of panels required will be:

$$N_m = \frac{P_{peak}}{\text{Module's Rating}} = \frac{1405.8}{420} = 3.35$$

For maximum output, especially during period of reduced solar irradiance, we can round the number of panels up to four (4). Therefore;

$N_m = 4$  Number of 420W PV modules, as depicted in Fig. 1.

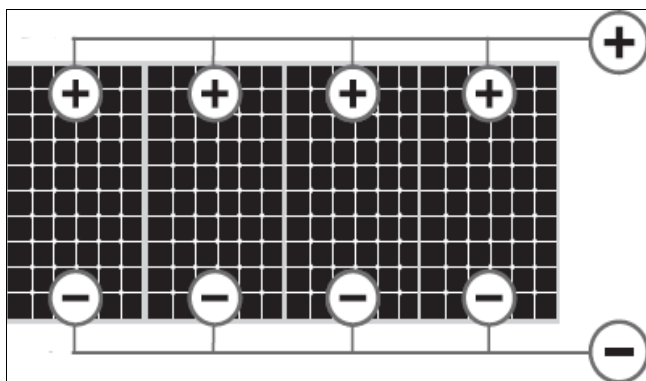

Fig 1: Parallel Connection of PV Modules

### Choice of inverter

An inverter is used in the PV power system to provide AC electric power to the already installed surface-mount water pump (Mirza & Gupta, 2022) [5]. The input rating of the inverter is not allowed to be lower than the total power of the different loads and must have the same nominal voltage as that of the battery bank (Ezhilvannan, *et al.*, 2023) [3]. In practice, the capacity of the inverter is given by;

$$P_{inv} = 1.25(P_{sum} + 3P_{ind}) \tag{4}$$

Where  $P_{inv}$  is the power of the inverter

$P_{sum}$  is the power of all non-inductive loads running simultaneously

$P_{ind}$  is the power of electric motor, which has a large starting torque.

The factor, 1.25 is multiplier that makes the inverter 25% larger in capacity, so as to allow for a reasonable future expansion. Neglecting  $P_{sum}$  in Equation (4) (since the other loads do not consume much power), the Equation can be re-written as;

$$P_{inv} = 1.25(3P_{ind}) = 3.75P_{ind}$$

Therefore,

$$P_{inv} = 1.25(3 \times 1500) = 3.75 \times 1500 = 5,625W$$

An inverter with the power rating of  $5500W$  can be selected to power the water pump (i.e.  $5.5 kW$  inverter).

### Charge controller

The solar charge controller sizing is generally based on current control. A good charge controller must be able to withstand the array current as well as the total load current and must be designed to match the voltage of the PV array as well as that of the battery bank (Mirzaei, *et al.*, 2017) [6]. The standard practice of sizing the charge controller is given by:

$$I_{CC} = I_{SC} \times N_{pm} \times F_{Safety}$$

Where;  $I_{SC}$  the short circuit current of the selected solar module

$N_{pm}$  is the number of parallel module strings

$F_{Safety}$  is the safety factor in order to allow for a reasonable system expansion.

The selected solar module for this research is the America's module company's MSE420SX6W and has a short circuit current given by;

$$I_{SC} = 11.05A$$

$$N_{pm} = 1$$

$N_{pm}$  is deduced after finding the total number of required modules using Equation (3), i.e.  $N_m = 4$ . Since a single string of four panels can be connected in parallel.

$F_{Safety} = 1.25$ . As a standard practice, normally a 125% safety factor is used to allow for reasonable future expansion. Therefore, the charge controller current for this research can be calculated as;

$$I_{CC} = I_{SC} \times N_{pm} \times F_{Safety} = 11.05 \times 1 \times 1.25 = 13.8A$$

But the controller current calculated above is for a single solar module. Therefore, by connecting 4 modules in parallel, the total charge controller current will be;

$I_{CC} = 4 \times 13.8 = 55.2A \cong 60A$  (Rounded up to the nearest whole number)

Therefore, a 60A charge controller can be used. Table 1 summarizes specification of the solar power components needed to power the 2 Hp electric motor.

**Table 1:** PV Solar Power Installation Components

S/N	Description of Item	Required Quantity
1	49.1Vdc, 420W MSE420SX6W Solar Module	4
2	48Vdc, 5.5kW, 100A MPPT Inverter	1
3	60/80A, 48Vdc, PC1800A series MPPT Solar Charge Controller	1
4	12Vdc, 200AH Deep Cycle Battery	4

**Water Level Detection**

The Grove ultrasonic ranger is an ultrasonic transducer that uses ultrasonic waves to measure distance. The Grove ultrasonic sensor module has an ultrasonic transmitter and receiver. When the 40kHz ultrasonic wave generated by the transmitter hits an object, the sound wave is reflected back and the receiver receives the reflected ultrasonic wave. It then calculates the time from the point of transmission to that of reception and multiplies it by the speed of sound in the air (i.e., 340 m/s) in order to calculate the distance from the sensor to the object. This is expressed mathematically as follows;

$$\text{Distance of object} = \text{echo signal high time} \times \text{sound speed} \left(\frac{340m/s}{2}\right)$$

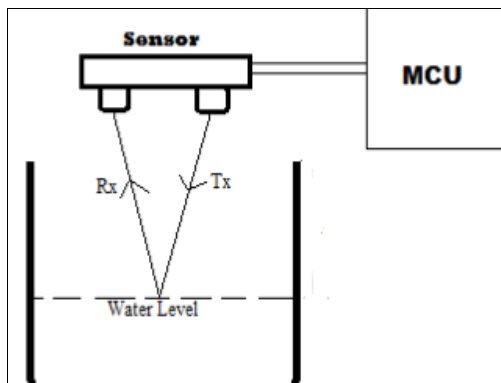

**Fig 1:** Water Level Detection using Ultrasonic Sensors

**Ultrasonic Distance Sensor A02YYUW**

The sensor used in this paper is a waterproof ultrasonic distance sensor A02YYUW. It is an easy to use, high quality distance sensor enclosed in a waterproof IP67 casing, which gives the sensor protection against dust and water, so that it can be used in harsh environmental conditions. Table 2 gives the specifications of the ultrasonic ranger and the A02YYUW, connected to an adapter cable SCN0311 is shown in Fig. 2.

**Table 2:** A02YYUW Ultrasonic Sensor Specifications

Parameter	Value/Range
Operating voltage	3.3 – 5V
Operating current	8mA
Ultrasonic frequency	40kHz
Measuring range	3 – 450cm
Resolution	3cm
Output	UART
Measurement angle	60 degrees
Working temperature	-25 – 80 degrees C



**Fig 2:** Ultrasonic Distance Sensor A02YYUW Connected to an Adapter Cable

**Water Pump Actuator**

The water pump switching unit comprised of a general-purpose TRIAC BT41 and an optocoupler 4N25 which are triggered by ATmega328P, wired up to emulate the Arduino. A program code for the execution of the water level detection and control is loaded to the chip for simplicity and compactness. The complete circuit for the water level detection is as shown in Fig. 3.

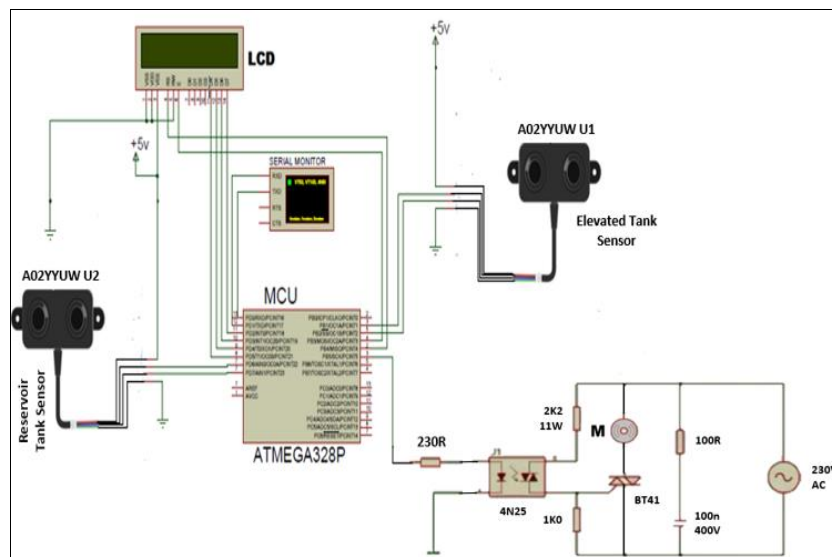

**Fig 3:** Simulation of Water Level Detection and Control

**Results and discussion**

In this paper we have designed and implemented a water level detection and control system for an elevated and reservoir tanks used to switch a 1.5 HP water pump. Both the elevated and reservoir tanks size six thousand liters (6000 liters) each. The tanks have height specification of **2020mm**. The working of the A02YYUW sensor was tested by filling the tank with water up to around **2000mm** level, with the sensor placed at bottom cover of the tank. The sensor reading was compared with an actual reading, measured using measuring tape. The water was drained and

both readings were repeatedly taken at distance intervals between the water and the sensor. The result of the measurements at different ambient temperatures is shown in Table 3.

The result shows that the accuracy of the sensor is affected by change in the ambient temperature. The sensor’s readings tend to increase with a corresponding increase in the ambient temperature, in comparison with the actual measurements. The result is depicted graphically in Figure 2.

**Table 3:** Water Level Detection of A02YYUW as Compared to the Actual Measurement at Different Temperatures

Actual Measurement(mm)	A02YYUW Measurement @ 14°C (mm)	A02YYUW Measurement @ 25°C (mm)	A02YYUW Measurement @ 30°C (mm)	A02YYUW Measurement @ 33°C (mm)	A02YYUW Measurement @ 36°C (mm)
300	290	296	305	308	312
500	496	501	511	511	513
1000	970	990	1005	1005	1010
1500	1489	1498	1510	1513	1515
2000	1985	1997	2009	2010	2011

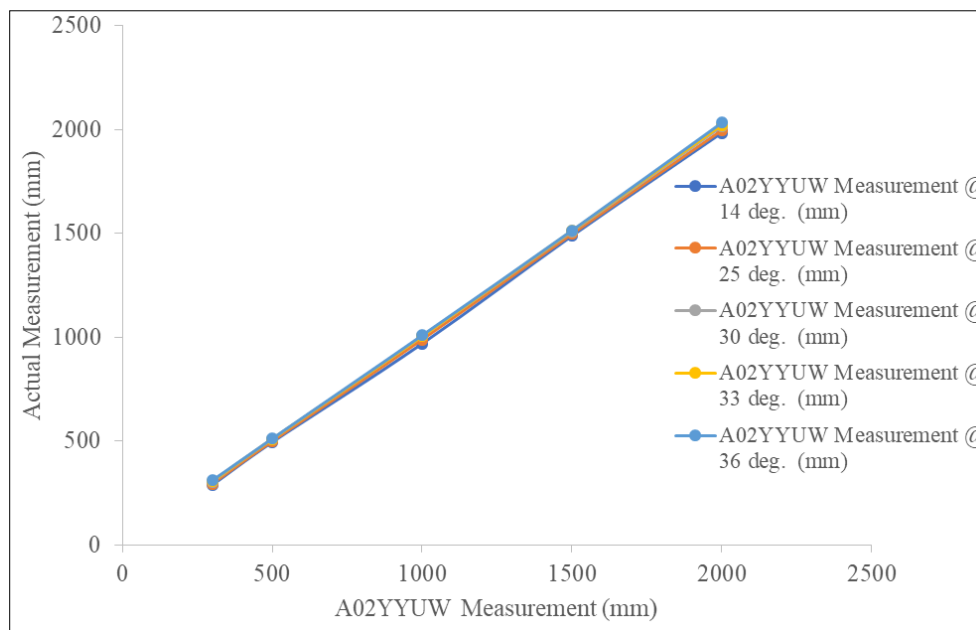

**Fig 2:** Actual Measurement against Sensor Measurements at Different Ambient Temperatures

**Conclusion**

The design and implementation of water level detection and control using a waterproof ultrasonic sensor, A02YYUW was considered in this paper. The waterproof capability, its ability to withstand a wide range of temperatures and input voltage ranges, give the sensor an upper hand over its predecessors, like the HC-SR04 and the grove ultrasonic sensors, used in previous literature. The sensor detects level of water in the tank and sends an appropriate signal to the microcontroller, either to switch the water pump on or off. The water level sensing of the A02YYUW was compared with the actual distance of the sensor from the water in the tank using a measuring tape. The results of the measurements showed that the deviation between the actual measurements and the expected values are very close, although the expected measurements were found to increase further away from the actual measurements with degree rise in the ambient temperature.

**Acknowledgement**

This work is part of an ongoing research funded by the Tertiary Education Trust Fund (TETFund) (constituted by the Federal Republic of Nigeria), under Institution-Based Research (IBR).

**References**

1. Argaw N, Foster R, Ellis A. *Renewable Energy for Water Pumping Applications in Rural Villages*, New Mexico: U.S. National Renewable Energy Laboratory, 2003.
2. Bamford E, Zadi D. Scaling up Solar Powered Water Supply: a review of experiences. *United Nations Children’s Fund (UNICEF)*, 2016, 1-24.
3. Ezhilvannan P, et al. Analysis of the Effectiveness of a Two-Stage Three-Phase Grid-Connected Inverter for Photovoltaic Applications. *Journal of Solar Energy Research*,2023;8(2):1471-1483.

4. Hamza AH, Yusuf MA, Musa IS. Standalone PV System Design and Sizing for a Household in Gombe, Nigeria. *International Journal of Interdisciplinary Research and Innovations*,2018:6(1):96-101.
5. Mirzaei A, *et al.* Design and Construction of a Charge Controller for Stand-alone PV/Battery Hybrid System by using a New Control Strategy and Power Management. *Solar Energy*,2017:149:132-144.
6. Mirza Z, Gupta N. Integration of Solar Power to the Electric Grid: A Case Study. *International Journal of Engineering, Science and Technology*,2022:14(3):78-84.
7. Ncube B, Pili O. Smallholder Farmer Coping and Adaptation Strategies for Agricultural Water Use During Drought Periods in the Overberg and West Coast Districts, Western Cape, South Africa. *Water SA*,2022:48(1):97-109.
8. Njoku M, *et al.* Solar Radiation Evaluation in North-East Geo-Political Zone of Nigeria. *ICONIC RESEARCH AND ENGINEERING JOURNALS*,2022:5(8):140-151.
9. Onoja SB, Isikwue MO, Malum JF. Physico-Chemical Characterization of Groundwater of Kaltungo, Gombe State, Nigeria And Treatment For Flouride Removal. *Nigerian Journal of Technology (NIJOTECH)*,2017:36(2):655-662.
10. Rashid MIM, Akorede MF, Chao LZ, Mohammed NFN. Dual-axis Solar Tracking System for Maximum Power Production in PV Systems. *Nigerian Journal of Technological Development*,2015:12(2):42-47.