



Hybrid charger controller based PV and wind turbine systems

M Irwanto¹, Taha A Taha², Abadal-Salam T Hussain³, M Masri⁴, H Alam⁵

^{1,4,5} Department of Electrical Engineering, Medan Institute of Technology, 20217 Medan, North Sumatera, Indonesia

^{1,2} School of Electrical System Engineering in University Malaysia Perlis (UniMAP), Pauh Putra Campus 02600 Arau, Perlis, Malaysia

³ Al-Kitab University College, Computer Technical Engineering, Alton Kupri, Kirkuk, Iraq

Abstract

The energy types corresponding to wind and sunlight are omnipresent, freely available, and inexhaustible in nature. Considering that of low wind speeds, the wind power might not be technically manageable in any respect sites. It is usually extra unpredictable than solar energy. The research about the hybrid controls between two power sources of wind turbines and solar cells, the output controller system charges batteries and loads while the charger controller system shows in LCD the temperature, power, energy, current for load and value for battery in duty cycle. This learns also highlights the longer term developments, which have the expertise to broaden the fiscal good looks of such programs and their acceptance by the consumer.

Keywords: solar energy, hybrid charger, PV, wind turbine systems

1. Introduction

The demand for electrical power is growing day by day, which are not able to be fulfilled by means of non-renewable energy sources on my own ^[1]. Renewable energy sources comparable of photovoltaic (PV) and wind turbine are omnipresent and environmental pleasant and The renewable energy sources are emerging options to fulfill the energy demand, however unreliable as a result of the stochastic nature of their prevalence and the hybrid renewable energy combines two or more renewable power sources like wind turbine and photovoltaic (PV) and The objective of this venture is to gift a complete assessment of quite a lot of points of hybrid

renewable energy and This prefeasibility analysis, most useful sizing, modeling, manipulate elements and reliability problems ^[1]. The applying of evolutionary procedure conception in hybrid renewable energy can also be awarded. The hybrid renewable energy in Fig. 1. Control system between two sources, the first input from photovoltaic (PV) and second input from wind turbine, the two sources are variable value. After take the source from photovoltaic (PV) and wind turbine the output for control system connect to input for charge controller system, the charger controller system for charging battery and use load shown in Fig. 1.

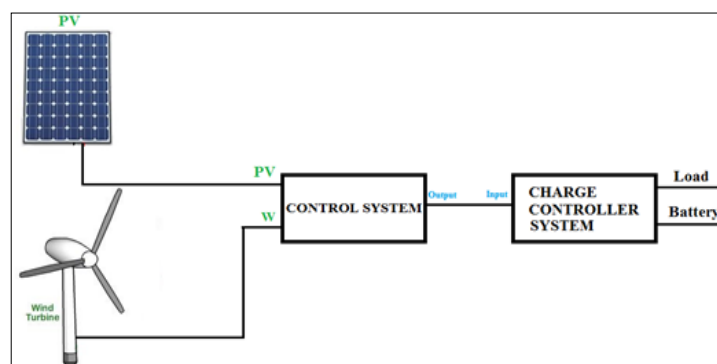

Fig 1 Hybrid Controller System

Electricity is the principal factor for industrialization, urbanization, financial growth of any nation ^[2]. There are exceptional types of traditional and non-traditional power sources used to generate electrical power. Sun and wind energy procedure one of the most distinguished sources of energy. The utilization of sun and wind power procedure has grown to be more and more preferred because of modular and atmosphere friendly nature ^[3]. The area of sunlight–wind has skilled a

terrific growth for earlier two a long time in its well-known use of standalone to utility interactive solar–wind techniques ^[4].

2. Methodology

2.1 Charger Controller System

The important point in the charger controller system is the Arduino Nano because this is the heart for the system. The Arduino Nano (MCU) senses for the PV voltage, output load

(current, power and energy) and battery voltages. It control the voltage for battery and PV and to decides to start charging or not charging the battery and control the load as well, all the steps for operation.

2.2 LCD 20x4 I2C

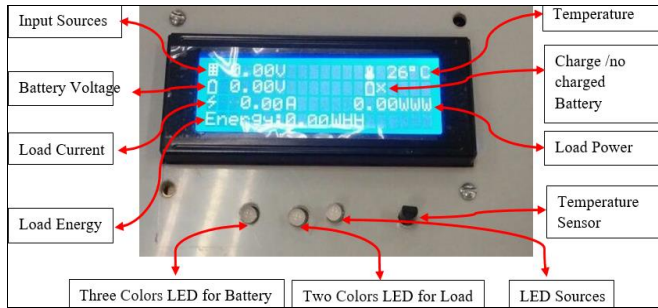

Fig 2: LCD for Charge Controller System

The LCD displays input sources from wind turbine, solar cell, and from output for system control as shown in Fig. 2. Battery voltage, temperature in celcius, photo for battery charge or nor charge and for load display. There are three values for load, first one is current value, and second one is energy load and power load that display by LCD 20x4 I2C as show in Fig. 2.

2.3 Load Control

The load control is automatically disconnect and connect the load by observation dawn or dusk of battery voltage, control for load is used. The use of the DC load in street light or normal light. When PV voltage more than 5V means dawn and when the PV less than 5V is mean dusk.

2.4 Automatic Connection (ON)

From 7 PM evening to 7AM morning, when the PV voltage level less than 5V and battery voltage is more than Low Voltage Disconnect (LVD), the controller system (Arduino) will connection automatically (ON) and the light of LED will be green for load, which means the load was applied.

2.5 Automatic disconnection (OFF)

From 7 AM morning to 7 PM night, when the PV voltage level more than 5V and battery voltage is less than Low Voltage Disconnect (LVD), the controller system (Arduino) will disconnected automatically (OFF), the light of the LED will be red for the load, which means the load wasn't been applied.

2.6 LED Load

In Tab. 1. A bi colors LED was used for load status (ON / OFF), two colors been used (red /green).

Table 1: LED Load

LED	Load Status
RED	OFF
GREEN	ON

2.7 Battery Indicator Using LED

The use of LED for battery indicator to see how much there are voltage or battery status, this is important point for user,

and used RGB LED because there are three colors options (red, green and blue) to as shown in Tab. 2.

Table 2: Battery LED

LED	Battery voltage
Blue	High
Green	Healthy
Red	Low

2.8 Control System between Two Sources

The system is automatically switch to the highest values voltage sources, use diodes, the suitable current value at 100W of 12V and maximum current is 10A, this means using big diodes. Cathodes tied together and Anodes to each power source. The highest power source will forward bias its diode and come through. The circuit show in Fig. 3. uses diode type is STPS20L25CT (TO-220AB). The $I_f(AV)$ 20A and $VRRM$ 25V and $T_j(max)$ 150C and $V_f(max)$ 0.25V, the highest voltage will come through. Schottky diode is suggested for least loss. Heat sink is suggested of aluminum [5].

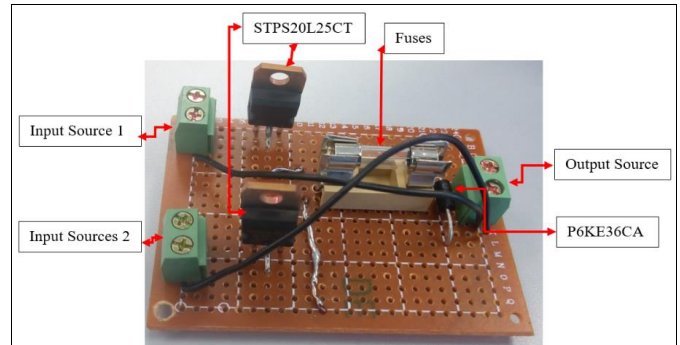

Fig 3: Control System between Two Sources

3. Result and Discussion

3.1 PV Testing Result for 4 Days

The graph shown in Fig. 4. For voltage output of 4 days duration from 27 to 30 April 2017 at Kangar, the condition variable value of voltage with time period, using of sun light as a source of energy. The data is proceeds of experiment for All 4 days starting from time period from 7 am until 7pm, where the value of voltage rises up from 0V till 15V maximum value. After this dramatically effect that will let voltage output will be in constant value until 3 pm of time period, while have high intensity of sun light and goes to low until 5 pm again, the reason with in sun light. And this condition of development that can make some changing referring to the graph design whether can make increased of measured condition or decreased measured condition. The graph in Fig. 4. Have some changing like some different effect can make the graph of uncomfortable in every day also that will let direction of development will be non- suitable condition. Also can say at second hand, the weather can determine design work referring back to phenomenon of area, and that will make technically measured for voltage, also can that depend to weather which is more important for such project. The best day is first day because increased voltage from mooring to 12pm, the maximum value of voltage from 12pm to 4pm of a value of 15V and again decrease the voltage

after 4pm. If need to get correct results will depend on how was used parameters, That things will give project works based on basic of correct testing, that will get correct result. The graph shown in Fig. 5. that shows for 4 days period from 27 to 30 April 2017 at Kangar, the condition of variable value of temperature with time period, At 7 am until 12 pm of time period, that the value of temperature rises up from 24° until 35° C and then temperature will be constant about until 4 pm and goes to be low until 24° C again, the reason with on light of sun. And this condition of development that can make some technically of change in our graph design whether make increased of measured condition or decreased measured condition. Correspondingly, the temperature refer is follow by the changing weather condition anymore. The graph shown in Fig. 4. have some changing like some different effects can make graph at uncomfortable zone also that will let direction of development will be an unsuitable condition. The best day for temperature was first day because when the temperature value will be high for voltage (15V). Also can say that at second hand, the weather condition can determine the work whether the make low or high measured value, at this condition got that weather is more important to project. Need to get correct results as it will depend on parameters. That will effect project works which based on basic of getting correct results, also that will make our calculations to be more verify

and depend on or follow the varies affection. Correspondingly, the temperature depending to the changing weather status. Also the temperature mostly vary to the time of day period. The graph shown in Fig. 6. Shows the irradiance, that data result plotted in Fig. 6. shows the irradiance goes at 4 days duration from 27 to 30 April 2017 at Kangar, start at time period 7 am till 10 am have risen up irradiance continuous at 1000 W/m² measure and keep continues rising until measure 1400 W/m² and become constant from 12pm until 5pm and then got decreasing due to the reason of low sun light. The collected data of irradiance shows the highest value of the irradiance was about of 1312 W/m² while the time period at around of 12 pm, where the sun at point of 90 degree on the earth surface. Some changes of data effects that makes graph uncomfortable and also that leads development to be not unsuitable condition. The best day was first day because the irradiance was at high value and the maximum irradiance value was about 1500 W/m². Technically, the weather can determine the work whether the measurement to be low or high measured, so the condition were very important in project. Correspondingly, while needed to get correct result as it is depend on how we use the parameters. That will lead the project works based on obtained correct result and also that will make our calculations to be verified and depend on or according the varies condition.

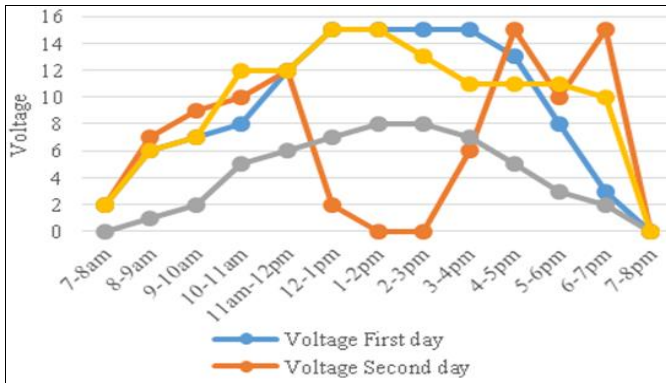

Fig 4: PV Testing Result for 4 days

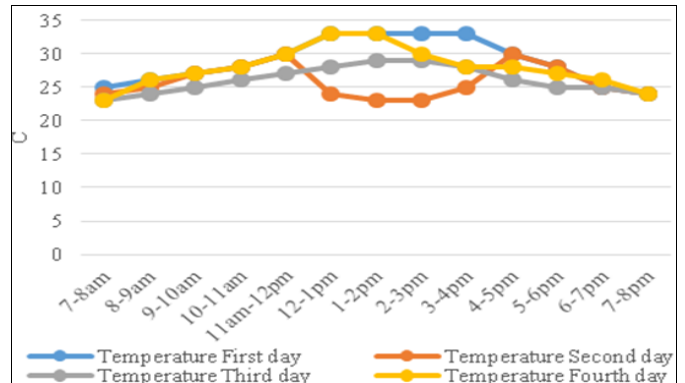

Fig 5: Temperature for 4 Days duration

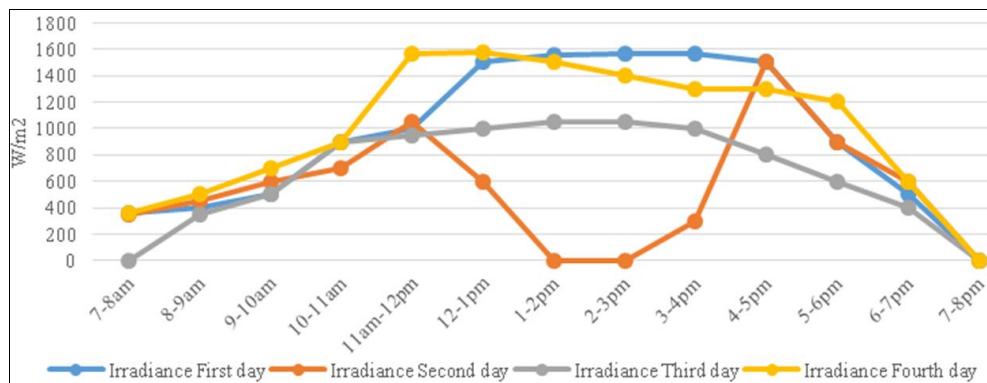

Fig 6: Irradiance for 4 Days duration

3.2 Wind Turbine Test Result for 4 Days duration

The graph shown in Fig. 7. was about the wind speed, it shows condition of speed of wind turbine that goes in 4 days from 27 to 30 April 2017 at Kangar, start from 7 am until 7am in 24 hours of time period of wind turbine with 12 high speed

reason which have high windy. After windy got below the speed will be decreased to ground until zero, the best day is second day because there are wind about over all day, raise up with high windy to about 11 Km/h of wind speed and then got decreased gradually, this condition that can make some

changes in graph design whether it increased or decreased measured condition. Need to get correct solution, it depends on how to use the parameters. That let our project works based on basic of obtained correct result and also that will make our calculations to be verified and depends on the varies effects. The graph shown in Fig. 8. About generated voltage by wind turbine from 27 to 30 April 2017 at Kangar, the high voltage value due to reason that have high windy day. After that got

low speed decreased gradually and this condition can make some change in graph shape in 4 days whether make it increased of or decreased measured condition. The beast day was the second day because all over the day there were a wind and in this day produce high voltage value, also that was leading to be a suitable condition. The weather can determines to get low or high measurements.

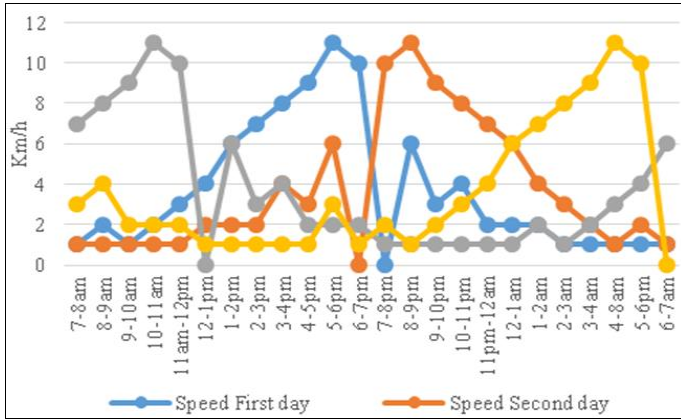

Fig 7: Wind Speed for 4 Days

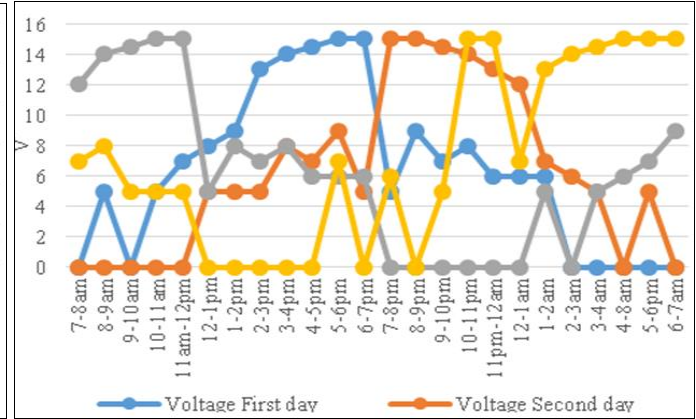

Fig 8: Voltage for 4 Days

3.3 Control Between to Sources PV and Wind Turbine in 4 Days

The graph shown in Fig. 9. That the value of PV and wind turbine were at different condition from 27 to 30 April 2017 at Kangar. At wind turbine part, from 7 am till 7am for 24 hours at no any action happen, during 12pm after have windy turban start moving to rise up continually it 15 V of measurement which goes for low PV part as shown in Fig. 10. Which was rise from 5V till there is no sun light at time 12pm, during 3 pm sun light back then PV rise up again then drop grandly until zero and this condition that can make some changes in graph design whether it increased or decreased measured condition. The graph shown in Fig. 10. that shows the output voltage value of PV and wind turbine were at different

condition from 27 to 30 April 2017 at Kangar. This condition of development that can make some changes in graph shape whether to increase or decreased measured condition. When the environment was at the right place to build true results, also that help to let direction of development will be at a suitable condition. The output voltage take the higher value from PV or wind turbine, the maximum value is 15 V. The weather can determine its condition that can make some changes in graph design whether it increased or decreased measured condition. Technically, need to get correct result it depends on the used parameters. These things let project works based on the correct result and also that will make our calculations to be verified and depends on the varies affection.

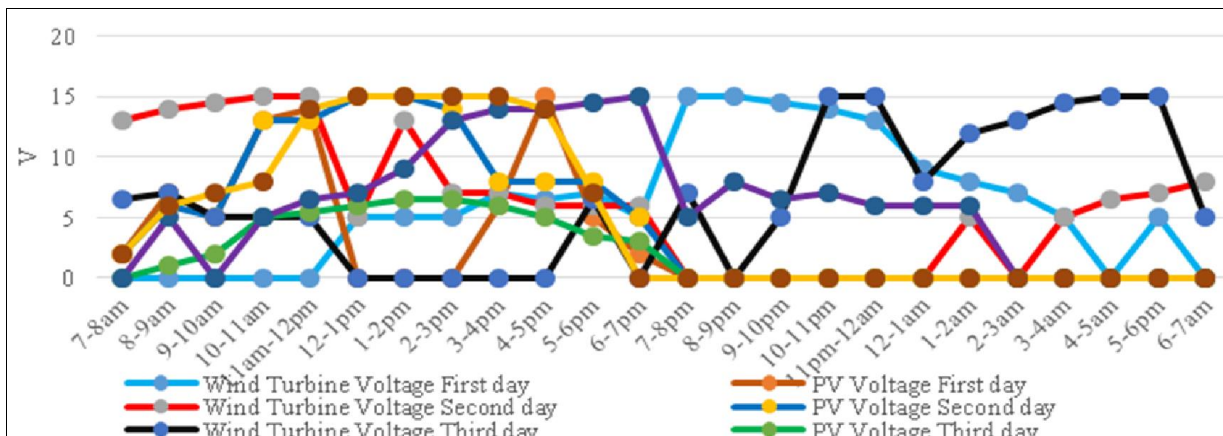

Fig 9: Voltage for Wind Turbine and PV for 4 Days

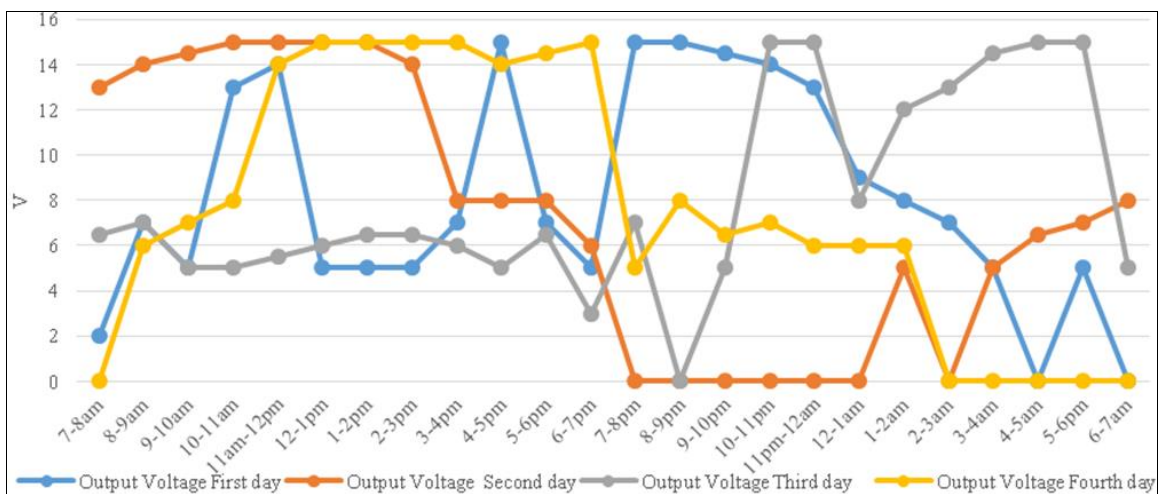

Fig 10: Output Voltage for Wind Turbine and PV for 4 Days

3.4 Charging battery from PV and wind turbine

The graph shown in Fig. 11. The charging battery from PV and wind turbine. Charging battery from PV and wind turbine of increment from 7 till 12 V with time about 6 hours, the time less than charging battery from PV in Fig. 11. and wind turbine shown in Fig. 11. Because add two sources for charging. The cement mode also and this condition of development that can make some change battery in graph design whether make it increased of measured condition. However, the last problem were faced in the implementation, was not able of the circuit to function properly while all of the other parts of the circuit was combined. In other hand, the circuit design was based on the selected value of component rating. If there was any different in the components value will be effect on circuit function accuracy which the same happened with result. This problem was solved by many ways for example, when do some changing on the component values in simulation which recalibration the circuit that refer to component that was used in the implementation.

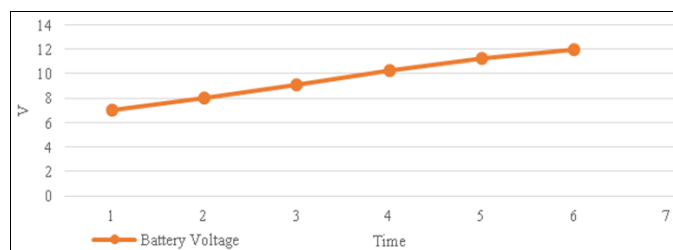

Fig 11: Charging Battery from PV and Wind Turbine

4. Conclusion

Finally, the design at a lower cost based on Arduino microcontroller, in other hand used to control between sources PV and wind turbine (hybrid system), simulated and constructed hardware system to control on charging process and protect battery at more safe condition of varies of voltage that maybe accrue during the charging processed as well as cutoff voltage when battery is fully charged and when discharge to its low level. All constructed based on measurement of feedback voltage form current load of that battery.

There were many methods of tests done on low voltage level of the design. Test were showed the circuit able to charging the battery as protect of the battery against the over and under voltage limits. There are two parts of tests were conducted on the circuit the first one was the implementation on board circuit and the other one based on the simulation of data result. The charging technically takes place when the battery voltage is in low level and high levels. However, the battery have to be full charged. Arduino detect the battery voltage level through the battery feedback sensor. The battery and interface circuit are enable the characteristic feature to control the charging time by control the charging current that supplied from the source. Another simulation result were obtained from the tests that conducted on the board circuit of the collection data form the results of experiment which was almost similar to the data collected after do simulation. However, the result shows the battery voltage level been controlled the charging current.

In conclusion an effect and embedded circuit design could be a better power supply that able to be used with sensitive device.

5. References

1. Vikas Khare, Savita Nema, Prashant Baredar, Solar-wind hybrid renewable energy system: A review, Renewable and Sustainable Energy Reviews. 2016; 58:23-33.
2. Khare V, Nema S, Baredar P. Status of solar-wind renewable energy in India. Renew Sustain Energy Rev. 2013; 27:1-10.
3. Elhadidy MA, Shaahid SM. Parametric study of hybrid (wind+solar+diesel) power generating systems. Renew Energy 2000; 21:129-39.
4. Nema S, Nema RK, Agnihotri G. Matlab/Simulink based study of photovoltaic cells/modules/array and their experimental verification. Int J Energy Environ. 2010; 1:487-500.
5. <https://forum.allaboutcircuits.com/forums/power-electronics-forum/>